

Installation, Operation, and Maintenance (IOM) Manual for ANSI Class 150 & 300 Flanged Ball Valves

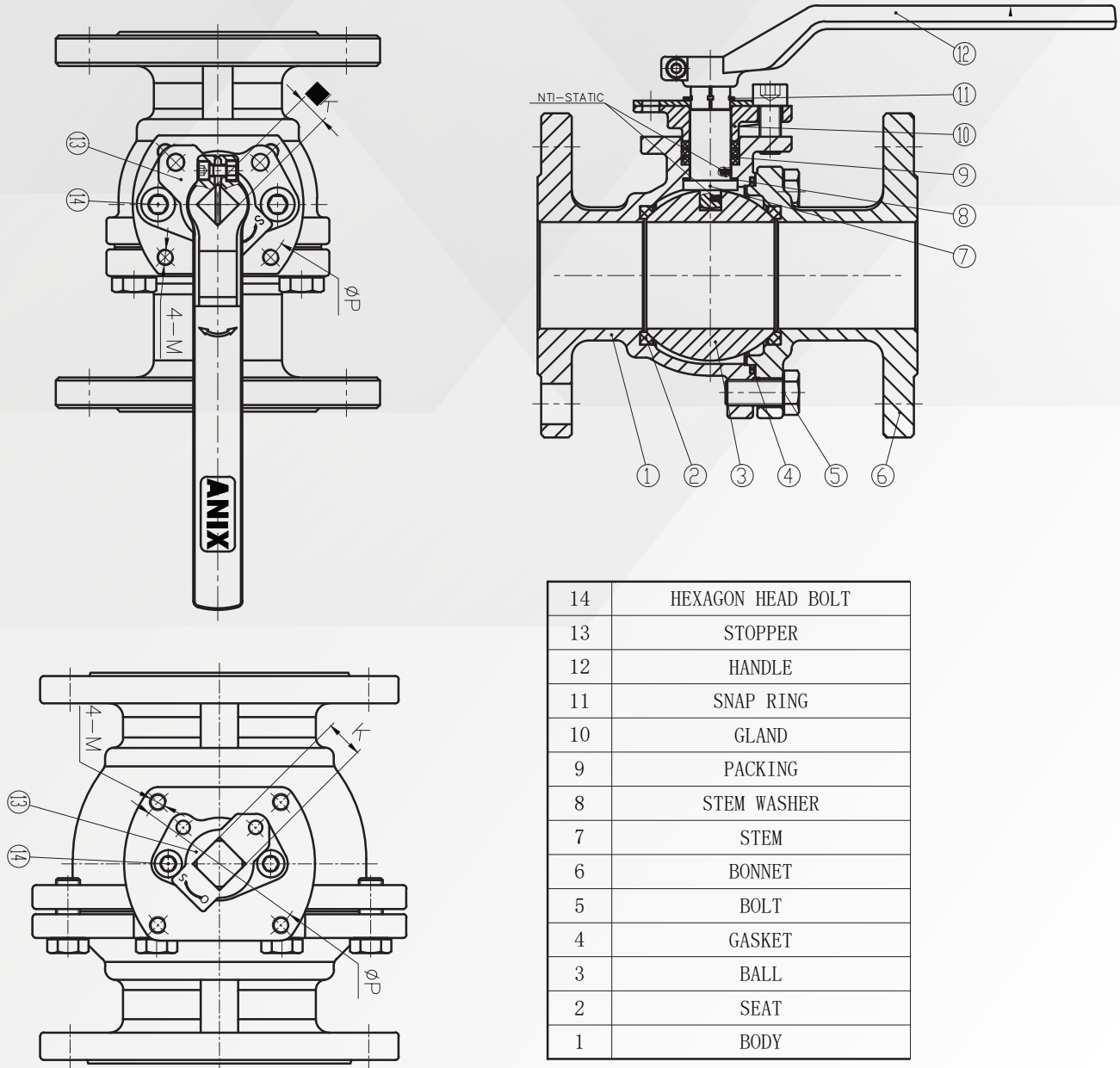

Refer to the diagram and parts list above for a detailed view of each component, assisting with installation, operation, and maintenance for optimal valve performance.



ANIX VALVE CO.LTD, Certified ISO 9001.

www.anixusa.com

Note: This document is a general guideline for the installation, operation, and maintenance of ANSI Class 150 & 300 Flanged Ball Valves, intended to assist trained personnel in following recommended procedures. It is not an exhaustive set of instructions. Carefully read the manual for safe and efficient use. We are not liable for damages arising from its use. Consult a professional if you have specific concerns related to your application or environment. For additional assistance, contact your supplier or representative.

PRODUCT OVERVIEW

- This line of ANSI Class 150 & 300 Flanged Ball Valves is designed with a split-body, two-piece construction, allowing easy access to the valve ball and seats. Utilizing a “free-floating” ball principle, the ball moves slightly with line pressure, enabling tight shut-off in both flow directions or dead-ended, regardless of valve position. In a closed position, the downstream seat bears the load, potentially extending seat life by reversing the valve in the pipeline.

INSTALLATION

- **A. Receiving and Preparation**
 - Shipping Protection: Remove any protective covers or packaging materials from the valve.
 - Inspection for Damage: Examine the valve for potential transportation damage.
 - Note: If damage is detected, take photographs and file a claim with the carrier.
 - Debris Removal: Check the valve bore and remove any debris.
 - Functional Check: Cycle the valve handle (if accessible) to ensure smooth operation.
 - Lubricant Notice: Valves may arrive with a light lubricant for initial break-in. If undesirable, it can be removed by disassembly and solvent cleaning.





ANIX VALVE CO.LTD, Certified ISO 9001.
www.anixusa.com

• B. Installation Procedure

- **General Guidelines:** The valve can be installed in any orientation within the pipeline. Ensure that the pipeline is free of debris, dirt, and welding slag before installation.
 - **Warning:** Do not use the valve as a structural support.
- **Positioning and Fastening:** Insert the valve between flanges, and tighten bolts gradually in a star pattern. Ensure flange compatibility with the valve type and pressure rating.
 - **Caution:** Ensure that mating flanges match the valve's size, type, and pressure rating, and use appropriate fasteners.
- **Actuator Alignment (if applicable):** Verify that any actuator is aligned with the valve to avoid high operational torque. Follow the actuator's specific installation guidelines for pneumatic or electric connections.
- **ISO5211 Mounting Pad:** This valve includes an ISO5211 mounting pad, which is designed for straightforward actuator attachment. However, a bracket and coupler are required to separate the actuator from the valve. This separation is crucial to allow for proper alignment and movement, reducing strain on both the valve and actuator, and enhancing durability.
- **During the bracket installation,** you may need to temporarily remove the packing stopper to provide adequate clearance. Once the bracket is in place, reinstall the packing stopper, following the balanced tightening method outlined above to maintain an even, secure seal.
- **To maintain a reliable seal and prevent leakage,** it is crucial to tighten the packing stopper bolts in a balanced way. Tighten each screw incrementally, moving from one screw to the next in a sequence rather than fully tightening one side first. This prevents uneven pressure, which could compromise the packing and lead to performance issues over time. Adjust each bolt little by little, ensuring a steady, even pressure distribution for a secure seal.

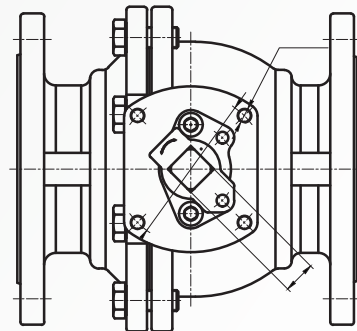
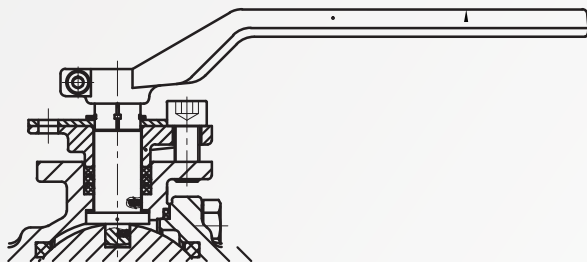



ANIX VALVE CO.LTD, Certified ISO 9001.

www.anixusa.com

OPERATION

• Manual Operation

- Handle Operation: Rotate the handle 90 degrees ($\frac{1}{4}$ turn) to operate
 - Open: Handle aligned with the pipeline.
 - Closed: Handle perpendicular to the pipeline.
- Automated Operation: The valve can be equipped with electric or pneumatic actuators. Refer to the actuator's IOM manual for specific operational instructions.
- Optional Accessories: Certain models may include limit switches or positioners. Refer to the IOM manual for each device for installation and operation guidance.

MAINTENANCE

• Important Safety Notices

- Caution: Ball valves may retain fluid in the cavity. Be prepared to handle any residual liquid when disassembling the valve.
- Warning: If the valve has been exposed to hazardous materials, review the relevant MSDS sheets and decontaminate the valve before proceeding. Ensure all personnel use appropriate personal protective equipment.

• A. Preparation for Maintenance

- Relieve Line Pressure: Ensure pressure is removed from the pipeline and turn the valve handle to a 45-degree position before disassembly.
- Actuator and Accessory Removal: Disconnect any actuators, switches, or positioners before maintenance. Isolate all power sources.

• B. Stem Packing Adjustment

- If stem seal leakage is detected, it may be corrected by tightening the packing gland nuts one flat at a time, alternating between nuts until leakage stops. If excessive torque is needed to operate the valve, replacement of the packing is recommended.
 - Warning: Do not remove the packing gland while the line is pressurized.



ANIX VALVE CO.LTD, Certified ISO 9001.

www.anixusa.com

• C. Valve Disassembly

- **Warning:** Do not attempt to repair or partially disassemble a valve while it is still in-line and under pressure. Ensure the pipeline is isolated, fully de-pressurized, and the valve is removed before starting maintenance
- **Pipeline Removal:** Carefully unbolt the valve from the pipeline, ensuring to use lifting straps for heavier valves. Take extra care to prevent any damage to the valve or surrounding components during removal.
- **Secure Work Area:** Place the valve on a stable, flat surface for disassembly. Protect the flange faces from scratches or damage during handling.
- **Mark and Disassemble:** To ensure proper reassembly, match-mark the body and body end for accurate alignment. Begin by removing the body end nuts, seats, and seals. Ensure the valve is in the fully closed position before proceeding with ball removal.
- **Ball Removal:** Handle the ball with caution to avoid any damage. Rotate the stem so the ball is in the fully closed position. Carefully lift the ball off the stem tang and remove it from the body using a rolling motion.
- **Stem Removal:**
 - **Smaller Valves:** Remove the handle, nut, lock washer, and packing follower.
 - **Smaller Valves:** Remove the handle, nut, lock washer, and packing follower.
- **Remove End Cap:** Use a spanner wrench to unscrew the end cap. One of the seats should come out along with the end cap.
- **Remove Body Seal:** Carefully remove the body seal from the valve.
- **Inspection and Cleaning:** Inspect all metal parts for wear or damage. Replace any worn components, including seats, seals, and packing.
- **Final Check:** Once disassembly is complete, ensure all parts are cleaned and inspected before reassembly. Only reassemble using new or verified serviceable parts.



ANIX VALVE CO.LTD, Certified ISO 9001.

www.anixusa.com

• D. Valve Reassembly

- Note: The valve can be assembled and operated dry if lubricants are not allowed in the system. However, applying a light lubrication to mating parts can facilitate assembly and reduce initial operating torque. Ensure that any lubricant used is compatible with the intended line fluid.
- Seat and Seal Installation: Install a new seat into the body cavity, ensuring the spherical curvature faces the ball. Follow with a new seal in the correct orientation to ensure proper sealing.
- Stem Installation: Place the thrust bearing onto the stem, then carefully slide the stem up through the body.
- Stem Components Installation: Install new stem seals, gland ring, and belleville springs. Then, install the gland nut and tighten it to the torque values provided in Table 1. Secure the gland nut with the locking tab or cap. If necessary, tighten the gland nut slightly to align it with the locking device surfaces.
- Ball Reinstallation: Place the ball in the fully closed position, ensuring proper alignment. Once in place, install the second seat and seal around the ball.
- Body End Assembly: Align the marked body and body end parts for proper reassembly. Tighten the body end nuts in a star pattern, following the recommended torque values.
- Note: Ensure the ball remains in the closed position before final tightening to avoid misalignment.
- Initial Operation Check: Slowly cycle the valve to confirm that the seal alignment is correct and the valve functions as intended.

REINSTALLATION

- Flange and Gasket Inspection: Clean flange faces and install new gaskets if needed.
- Final Installation: Position the valve and tighten bolts to recommended torque in a star pattern.